

# MEGA MITE

Powerful Performance in a Compact Profile

## When You Need Quality and Reliability in Tight Spaces

The industrial grade kingpin, poured urethane wheel, and precision bearing empower this tiny titan to roll smoothly and easily, even under the heaviest loads.

### Applications:

- Data Centers
- Food Service
- Store Fixtures
- Business Machines

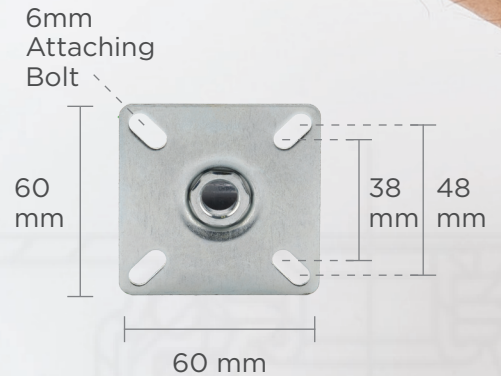

**Incredibly Low Mounting Height**

**250 lb. Max Load Capacity per Caster**

**Industrial Grade Build Construction**

Part Number	Wheel Size	Description	Capacity	Top Plate	Load Height
M2.3302.938	35 mm	Swivel	250 lbs.	60 x 60 mm	52 mm