



*Committed to your success!®*



**MINI-CATALOG  
2025**



FOOD SERVICE CASTER  
**EXPERTS**  
COMMITTED TO YOUR SUCCESS



# Contents

## Jarvis Limited Warranty Policy

Jarvis caster products are warranted against defects in material and workmanship for a period of one (1) year from the date of original purchase. Any product found to be defective by Jarvis Caster Company due to material or workmanship, returned with the prior written authorization of Jarvis' Quality Control Department, within the warranty period, will be repaired or replaced free of charge, non-inclusive of freight and installation.

This Limited Warranty does not include any product that has not been used for the purpose intended, or any product that has been abused, misused, mishandled, altered, or improperly installed. Jarvis Caster's obligation under this Limited Warranty is limited to repair, replacement, or refund of the purchase price at the sole discretion of Jarvis Caster.

*This Limited Warranty is provided in lieu of all other warranties, express or implied, and all other warranties of merchantability and fitness for a particular purpose, are hereby excluded and disclaimed.*

## Introduction

Contents.....	3
Wheel Selection.....	3
Jarvis Model Numbers.....	4

## Light Duty 30-40 Series Casters

30-40 Series Casters.....	5-8
30/31 Series Swivel & Rigid Top Plate	
30 Series Octagon Stem	
34 Series Spring Ring/Octagon Stem	
36 Series Threaded / Pipe Stem	
40 Series Expanding Adapter Stem	
3S Series Hollow Kingpin	

## Light Duty Stainless Steel S30-S40 Series Casters

S30-S40 Series Casters.....	9-10
S30/S31 Swivel & Rigid Top Plate	
S32 Round Stem	
S34 Spring Ring Stem	
S36 Threaded Stem	
S40 Expanding Adapter Stem	

## Medium Heavy Duty 130-136 Series Casters

130-136 Series Casters.....	11-12
130/131 Series Swivel & Rigid Top Plate	
134 Series Spring Ring Stem	
136 Threaded Stem	

## Options / Accessories

Bumpers.....	13
Applicators / Adapters.....	13
Plate and Stem Mounting Options.....	14



Consult the NSF listing page on a part specific basis for NSF requirements, part specific basis.

# Wheel Selection



5-105

(shown in photo)

### Cushion or Hard / Solid Rubber

Cushion or hard rubber tread. Conductive models available. Capacity up to 400 lbs.



5-452

(shown in photo)

### Cushion / Solid Rubber with Decorative Side Plates

Cushion Rubber tread with decorative metal side plates. Grey wheels available. Capacity up to 230 lbs.

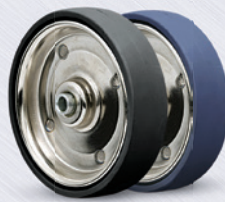

5-113 & 5-113P

(shown in photo)

### Welded Disc / Rubber & Polyurethane

Neoprene rubber or blue polyurethane tread compressed between two steel discs welded together. Capacity up to 250 lbs.



5-213GF & 5-213GD

(shown in photo)

### Advantage™ TPR

Flat grey special modulus TPR tread bonded to polyolefin wheel core. Capacity up to 400 lbs.



5-213RTF & 5-213RTR

(shown in photo)

### Advantage™ Heat

Flat red modulus TPR tread bonded to polyolefin wheel core. Capacity up to 325 lbs.



5-213MF

(shown in photo)

### Advantage™ Health Antimicrobial

Flat light blue modulus TPR tread bonded to polyolefin wheel core. Capacity up to 325 lbs.



5-513

(shown in photo)

### Polyolefin

Light weight yet durable hard tread solid polyolefin construction. Capacity up to 400 lbs.



5-521 NHT

(shown in photo)

### Hi-Temp Resin

Exclusive blended resin compound is designed to withstand the extreme high-temperatures required by certain industries and applications. Capacity up to 325 lbs.



5-213G & 5-213P

(shown in photo)

### PolyLoc™/ Grey Polyurethane

Grey or blue polyurethane tread mechanically locked to polyolefin wheel core. Capacity up to 400 lbs.



6-222

(shown in photo)

### Phenolic

Hard tread wheels made of compression molded phenolic resin filled with macerated fabric. High temperature models available. Capacity up to 400 lbs.

# Jarvis Model Numbers

## Casters

Below model is a 5" wheel diameter 30 Series swivel caster with Flat Tread Advantage wheel with VertiLoc® brake.

# 5-30-213GF VL

Wheel  
Diameter  
(Inches)

Caster  
Series

Wheel  
Type

Wheel Code	
C	Conductive Tread
G	Grey Tread
F	Flat Tread
D	Donut Tread (Round)
N	Neoprene Tread
P	Polyurethane Blue Tread

Option Code	
VL	VertiLoc®
PL	PosiLoc® Brake
SB	Side Brake
SL	Swivel Lock
1PSL	Swivel Lock
GS	Grease Seal
TG	Thread Guards

## Wheels

Below model is a 5" wheel diameter Flat Tread Advantage wheel with ball bearing.

# 5-213GF

Wheel  
Diameter  
(Inches)

Wheel  
Type

Wheel Code	
C	Conductive Tread
G	Grey Tread
F	Flat Tread
D	Donut Tread (Round)
N	Neoprene Tread
P	Polyurethane Blue Tread

## Forks

Below model is a 5" diameter 30 Series swivel fork.

# 5-30-000-PLT 2

Wheel  
Diameter  
(Inches)

Caster  
Series

Plate or  
Stem Size



# Light Duty 30 to 40 Series

Capacity to 325 pounds each



5-36-113P STEM 2  
*(shown in photo)*

5-30-213GF PLT2  
*(shown in photo)*



## FEATURES

- ✓ **Finish:** bright zinc plating to resist rust and corrosion.
- ✓ **Design:** heavy gauge cold rolled steel, formed for strength.
- ✓ **Dust Cap:** all swivel models feature dust cap which protects swivel raceway bearings and improves performance.
- ✓ **Swivel Construction:** double ball bearing with hardened raceways.
- ✓ **Axle:** 3/8" diameter bolt with lock nut.
- ✓ **King Pin:** 1/2" steel rivet, hydraulically upset.



Please work with your sales representative for compliance requirements on a part specific basis.

## CASTER OPTIONS

- ✓ **Bright Nickel Plating:** to order, add "5" to body of model number (Example: 5-305-105). **Other finishes available.**
- ✓ **PosiLoc® Brake:** all stainless steel construction. To order, add "PL" to end of model number (not available on 2-1/2" wheel models). 
- ✓ **VertiLoc® Brake:** to order, add "VL" to end of model number (not available on 2-1/2" wheel models). 
- ✓ **Swivel Lock:** Locks caster in trailing position at 180° while wheel spins freely. To order specify "1PSL" (swivel plate only). 
- ✓ **Precision Ball Wheel Bearing:** Sealed precision ball bearing available for most wheels—consult factory.
- ✓ **Swivel Grease Seal:** Includes zerk grease fitting in dust cap. To order, add "GS" to end of model number. 
- ✓ **Thread Guards:** Consult factory

## OPTIONAL FINISHES

In addition to our standard zinc and nickel plating, Jarvis offers the industry's largest selection of special plating and finish options. These special finishes can enhance the appearance of your equipment or offer extra protection in harsh environments. Shown below is a representative sampling of a few of these optional finishes. Please consult factory for pricing and availability.



30-40 SERIES

# Light Duty 30 to 40 Series

Capacity to 325 pounds each

## WHEEL OPTIONS



These charts are designed to provide the user a general comparison of Jarvis wheel types on a variety of floor surfaces and under a wide range of operating conditions. For specific applications or unusual conditions, please consult factory (chart is valid for 30 to 136 series casters).

Wheel Type	Capacity Range Per Wheel	Temperature Range	Hardness
CUSHION / SOLID RUBBER	Up to 260 lbs.	-30° to +160° F	75 (±) 5 (A)
HARD / SOLID RUBBER	Up to 400 lbs.	-30° to +160° F	75 (±) 5 (D)
ADVANTAGE TPR (INCLUDING HEAT / HEALTH)	Up to 400 lbs.	-40° to +180° F	65 (±) 5 (A)
WELDED DISC / RUBBER	Up to 250 lbs.	-40° to +160° F	75 (±) 5 (A)
WELDED DISC / POLYURETHANE	Up to 300 lbs.	-40° to +180° F	95 (±) 5 (A)
POLYOLEFIN	Up to 400 lbs.	-20° to +180° F	65 (±) 5 (D)
PHENOLIC	Up to 400 lbs.	-45° to +250° F	90(±) 5 (D)
POLYLOC POLYURETHANE	Up to 400 lbs.	-30° to +180° F	95 (±) 5 (A)
HI-TEMP RESIN	Up to 400 lbs.	-20° to +475° F	75 (±) 5 (D)

Standard Jarvis grease temperature range:  
-45°F to +260°F.

## Floor Surfaces

Wheel Type	Carpet	Brick	Concrete	Linoleum	Asphalt	Terrazzo	Wood	Smooth Steel	Ribbed Steel	Tile
CUSHION / SOLID RUBBER	✓	✓	✓	✓	✓	✓	✓	✓	✓	✓
HARD / SOLID RUBBER	✓	✓	✓	✓	✓	✓	✓	✓	✓	✓
ADVANTAGE TPR (INCLUDING HEAT / HEALTH)	✓	✓	✓	✓	✓	✓	✓	✓	✓	✓
WELDED DISC / RUBBER	✓	✓	✓	✓	✓	✓	✓	✓	✓	✓
WELDED DISC / POLYURETHANE	✓	✓	✓	✓	✓	✓	✓	✓	✓	✓
POLYOLEFIN	✓	✓	✓	✓	✓	✓	✓	✓	✓	✓
PHENOLIC	✓	✓	✓	✓	✓	✓	✓	✓	✓	✓
POLYLOC POLYURETHANE	✓	✓	✓	✓	✓	✓	✓	✓	✓	✓
HI-TEMP RESIN	✓	✓	✓	✓	✓	✓	✓	✓	✓	✓

## Operating Conditions

Wheel Type	Water	Steam	Mild Chemicals	Oil/Grease	Metal Chips	High Heat > +250°F	Extreme Cold -20°F	Animal Fats	Noise Reduction	Floor Protection	Shock Absorption
CUSHION / SOLID RUBBER	✓	✓	✓	✓	✓	✓	✓	✓	✓	✓	✓
HARD / SOLID RUBBER	✓	✓	✓	✓	✓	✓	✓	✓	✓	✓	✓
ADVANTAGE TPR (INCLUDING HEAT / HEALTH)	✓	✓	✓	✓	✓	✓	✓	✓	✓	✓	✓
WELDED DISC / RUBBER	✓	✓	✓	✓	✓	✓	✓	✓	✓	✓	✓
WELDED DISC / POLYURETHANE	✓	✓	✓	✓	✓	✓	✓	✓	✓	✓	✓
POLYOLEFIN	✓	✓	✓	✓	✓	✓	✓	✓	✓	✓	✓
PHENOLIC	✓	✓	✓	✓	✓	✓	✓	✓	✓	✓	✓
POLYLOC POLYURETHANE	✓	✓	✓	✓	✓	✓	✓	✓	✓	✓	✓
HI-TEMP RESIN	✓	✓	✓	✓	✓	✓	✓	✓	✓	✓	✓



30 Series Swivel

31 Series Rigid

32 Octagon Stem

34 Series Spring Ring Stem

36 Series Threaded Stem

38 Series Pipe Thread Stem

40 Series Expanding Adapter Stem

3S Hollow Rivet

30-40 SERIES



# Light Duty 30 to 40 Series

Capacity to 325 pounds each

Wheel Diameter (Inches)	Tread Width (Inches)	Wheel Type	Bearing	Capacity (Pounds)	Base Model Number	Approximate Weight (Pounds)	Load Height (Inches)	Swivel Radius (Inches)
2 1/2	1 1/4	CUSHION RUBBER	DELTRIN	140	2-1/2-___-105	1-11/16	3 5/8 (Plate) 3 7/16 (Stem)	2 3/4
		HARD RUBBER	DELTRIN	210	2-1/2-___-106	1-11/16		
		POLYOLEFIN	PLAIN	210	2-1/2-___-513	1-11/16		
3	1 1/4	CUSHION RUBBER	DELTRIN	150	3-___-105	1-3/4	4 1/8 (Plate) 3 7/16 (Stem)	3
		CUSHION RUBBER	BALL	150	3-___-152	1-3/4		
		HARD RUBBER	DELTRIN	220	3-___-106	1-3/4		
		HARD RUBBER	BALL	220	3-___-162	1-3/4		
	POLYOLEFIN	PLAIN	250	3-___-521	1-3/4			
1 1/2	PHENOLIC	PLAIN	300	3-___-121	1-3/4			
3 1/2	1 1/4	CUSHION RUBBER	DELTRIN	160	3-1/2-___-105	2	4 5/8 (Plate) 4 7/16 (Stem)	3 1/4
		CUSHION RUBBER W/ SIDE PLATES*	BALL	160	3-1/2-___-452*	2		
		WELDED DISC / BLACK RUBBER	BALL	200	3-1/2-___-113	2-3/16		
		WELDED DISC / GREY RUBBER	BALL	225	3-1/2-___-113G	2-3/16		
		ADVANTAGE TPR / ROUND	DELTRIN	225	3-1/2-___-314GD	2-3/16		
		ADVANTAGE TPR / ROUND	BALL	225	3-1/2-___-213GD	2-3/16		
		ADVANTAGE HEAT ROUND	S.S. BALL	225	3-1/2-___-213RTR	2-3/16		
		ADVANTAGE HEAT FLAT	S.S. BALL	225	3-1/2-___-213RTF	2-3/16		
		ADVANTAGE HEALTH	S.S. BALL	225	3-1/2-___-213MF	2-3/16		
3 1/2	1 1/4	HARD RUBBER	DELTRIN	230	3-1/2-___-106	2	4 5/8 (Plate) 4 5/8 (Stem)	3 1/4
		HARD RUBBER W/ SIDE PLATES*	BALL	230	3-1/2-___-462*	2-3/16		
		POLYOLEFIN	PLAIN	250	3-1/2-___-513	2-3/16		
		HI-TEMP RESIN	PLAIN	250	3-1/2-___-521HTN	2-1/2		
		WELDED DISC / POLYURETHANE	BALL	250	3-1/2-___-113P	2-3/16		
		ADVANTAGE TPR / FLAT	DELTRIN	250	3-1/2-___-314GF	2-3/16		
		ADVANTAGE TPR / FLAT	BALL	250	3-1/2-___-213GF	2-3/16		
		POLYLOC / GREY	BALL	250	3-1/2-___-213G	2-3/16		
		POLYLOC / GREY	DELTRIN	250	3-1/2-___-314G	2-3/16		
		POLYLOC / BLUE	BALL	250	3-1/2-___-213P	2-3/16		
4 Continues next page	1 1/4	CUSHION RUBBER	DELTRIN	170	4-___-105	2-3/8	5 1/8 (Plate) 4 15/16 (Stem)	3 1/2
		CUSHION RUBBER W/ SIDE PLATES*	BALL	170	4-___-452*	2-3/8		
		WELDED DISC / BLACK RUBBER	BALL	200	4-___-113	2-1/2		
		WELDED DISC / GREY RUBBER	BALL	200	4-___-113G	2-1/2		
		HARD RUBBER	DELTRIN	250	4-___-106	2-3/8		
		HARD RUBBER W/ SIDE PLATES*	BALL	250	4-___-462*	2-3/8		
		ADVANTAGE TPR / ROUND	DELTRIN	250	4-___-314GD	2-1/2		
		ADVANTAGE TPR / ROUND	BALL	250	4-___-213GD	2-1/2		
		WELDED DISC / POLYURETHANE	BALL	275	4-___-113P	2-1/2		
		POLYLOC / GREY	BALL	275	4-___-213G	2-1/2		
		POLYLOC / GREY	DELTRIN	275	4-___-314G	2-1/2		
		POLYLOC / BLUE	BALL	275	4-___-213P	2-1/2		
		POLYOLEFIN	PLAIN	275	4-___-513	2-1/2		
		ADVANTAGE TPR / FLAT	DELTRIN	300	4-___-314GF	2-1/2		
		ADVANTAGE TPR / FLAT	BALL	300	4-___-213GF	2-1/2		
		ADVANTAGE HEAT ROUND	S.S. BALL	300	4-___-213RTR	2-1/2		
		ADVANTAGE HEAT FLAT	S.S. BALL	300	4-___-213RTF	2-1/2		
		ADVANTAGE HEALTH	S.S. BALL	300	4-___-213MF	2-1/2		
	1 1/2	PHENOLIC	PLAIN	300	4-___-121	2-1/2		
	1 1/2	HI-TEMP RESIN	PLAIN	300	4-___-521HT	2-1/2		

To order, add caster series and if applicable the mounting code to end of model number (Example: 5-30-105 PLT 1 or 5-34-213G STEM 1). See next page for details.

## WHEEL OPTIONS



Cushion or Hard Rubber



Conductive Rubber



Cushion or Hard Rubber w/Side Plates

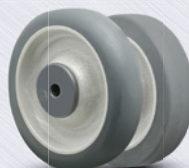

Advantage TPR Round and Flat



Advantage Heat Flat or Round

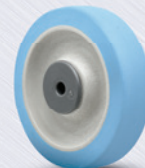

Advantage Health Antimicrobial



Welded Disc Blue Poly, Black or Grey Rubber



Polyolefin



Phenolic



PolyLoc Grey or Blue



Hi-Temp Resin









Continues next page

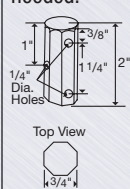

30-40 Series

Wheel Diameter (Inches)	Tread Width (Inches)	Wheel Type	Bearing	Capacity (Pounds)	Base Model Number	Approximate Weight (Pounds)	Load Height (Inches)	Swivel Radius (Inches)
5 Continues from previous page	1 1/4	CUSHION RUBBER	DELRIN	200	5-___-105	2-3/4	6 1/4 (Plate) 6 1/16 (Stem)	4
		CONDUCTIVE CUSHION RUBBER	SINTERED	200	5-___-105C	2-3/4		
		CUSHION RUBBER	BALL	200	5-___-152	2-3/4		
		CUSHION RUBBER W/ SIDE PLATES*	BALL	200	5-___-452*	2-3/4		
		WELDED DISC / BLACK RUBBER	BALL	200	5-___-113	3		
		WELDED DISC / GREY RUBBER	BALL	200	5-___-113G	3		
		ADVANTAGE TPR / ROUND	DELRIN	250	5-___-314GD	3		
		ADVANTAGE TPR / ROUND	BALL	250	5-___-213GD	3		
		HARD RUBBER	DELRIN	280	5-___-106	2-3/4		
		HARD RUBBER	BALL	280	5-___-162	2-3/4		
		HARD RUBBER W/ SIDE PLATES*	BALL	280	5-___-462*	2-3/4		
		WELDED DISC / POLYURETHANE	BALL	300	5-___-113P	3		
		POLYLOC / GREY	BALL	300	5-___-213G	3		
		POLYLOC / GREY	DELRIN	300	5-___-314G	3		
		POLYLOC / BLUE	BALL	300	5-___-213P	3		
		POLYOLEFIN	PLAIN	300	5-___-513	3		
		POLYOLEFIN	BALL	300	5-___-514	3		
		ADVANTAGE HEAT ROUND	S.S. BALL	300	5-___-213RTR	3		
	ADVANTAGE HEAT FLAT	S.S. BALL	300	5-___-213RTF	3			
	ADVANTAGE HEALTH	S.S. BALL	300	5-___-213MF	3			
ADVANTAGE TPR / FLAT	DELRIN	325	5-___-314GF	3				
ADVANTAGE TPR / FLAT	BALL	325	5-___-213GF	3				
1 1/2	PHENOLIC	PLAIN	300	5-___-121	3			
	HI-TEMP RESIN	PLAIN	325	5-___-521NHT	3			
6	1 1/4	CUSHION RUBBER	DELRIN	220	6-___-105	3-1/8	7 1/4 (Plate) 7 1/16 (Stem)	4 1/2
		CONDUCTIVE CUSHION RUBBER	SINTERED	220	6-___-105C	3-1/8		
		WELDED DISC / BLACK RUBBER	BALL	250	6-___-113	3-3/4		
		WELDED DISC / GREY RUBBER	BALL	250	6-___-113G	3-3/4		
		HARD RUBBER	DELRIN	300	6-___-106	3-1/8		
		HARD RUBBER	BALL	300	6-___-162	3-1/8		
		WELDED DISC / POLYURETHANE	BALL	300	6-___-113P	3-3/4		
		ADVANTAGE TPR / ROUND	DELRIN	300	6-___-314GD	3-3/4		
		ADVANTAGE TPR / ROUND	BALL	300	6-___-213GD	3-3/4		
		POLYLOC / GREY	BALL	300	6-___-213G	3-3/4		
		POLYLOC / GREY	DELRIN	300	6-___-314G	3-3/4		
		POLYLOC / BLUE	BALL	300	6-___-213P	3-3/4		
	ADVANTAGE HEAT ROUND	S.S. BALL	325	6-___-213RTR	3-3/4			
	ADVANTAGE HEAT FLAT	S.S. BALL	325	6-___-213RTF	3-3/4			
	ADVANTAGE HEALTH	S.S. BALL	325	6-___-213MF	3-3/4			
	1 1/2	PHENOLIC	PLAIN	300	6-___-121	3-3/4		
		POLYOLEFIN	PLAIN	300	6-___-521	3-3/4		

To order, add caster series and mounting code to end of model number (Example: 5-30-105 **PLT 1** or 5-34-213G **STEM 1**)

<p><b>30 Series Swivel</b> Specify "30"</p>  <p><b>PLT 1</b> Dimensions: 2-3/8" x 3-5/8" Bolt Pattern: 1-3/4" x 3" (bolt size 1/4")</p> <p><b>PLT 2</b> Dimensions: 2-3/8" x 3-5/8" Bolt Pattern: 1-3/4" x 3" (bolt size 5/16")</p> <p><b>PLT 3</b> Dimensions: 3-1/8" x 4-1/8" Bolt Pattern: 2-3/8" x 3-7/16" (bolt size 5/16")</p> <p><b>PLT 4</b> Dimensions: 4" x 4" Bolt Pattern: 3" x 3" (bolt size 3/8")</p> <p><b>PLT 5</b> Dimensions: 3-3/4" x 4-1/2" Bolt Pattern: 2-5/8" x 3-5/8" to 3" x 3" (bolt size 3/8")</p> <p><b>PLT 7</b> Dimensions: 3-1/2" x 3-1/2" 2-5/8" x 2-5/8" (bolt size 9/32")</p> <p>Note: PLT 4 and PLT 5 rigid casters are two piece welded design. Consult factory.</p>	<p><b>31 Series Rigid</b> Specify "31"</p> 	<p><b>32 Series Octagon Stem</b> Specify "32"</p>  <p>3/4" octagon x 2" long with three cross drilled mounting holes 1/4" dia. Stem code not needed.</p>  <p>Top View</p>	<p><b>34 Series Spring Ring Stem</b> Specify "34"</p>  <p><b>STEM 1</b> 3/4" diameter x 2-3/16" long</p> <p><b>STEM 2</b> 13/16" diameter x 2-3/16" long</p> <p><b>STEM 3</b> .845" diameter x 2-3/16" long</p> <p><b>STEM 4</b> .865" diameter x 2-3/16" long</p> <p><b>STEM 5</b> 1" diameter x 2-3/16" long</p> <p><b>STEM 6</b> .860" SQUARE x 2-3/16" long</p>	<p><b>36 Series Threaded Stem</b> Specify "36"</p>  <p><b>STEM 1</b> 1/2" dia. -13 x 3/4" long</p> <p><b>STEM 2</b> 1/2" dia. -13 x 1" long</p> <p><b>STEM 3</b> 1/2" dia. -13 x 1-1/2" long</p> <p><b>STEM 4</b> 1/2" dia. -20 x 3/4" long</p> <p><b>STEM 5</b> 1/2" dia. -20 x 2-1/4" long</p> <p><b>STEM 6</b> 5/8" dia. -11 x 1-1/4" long</p> <p><b>STEM 7</b> 5/8" dia. -18 x 1-3/4" long</p> <p><b>STEM 8</b> 3/4" dia. -10 x 1" long</p>	<p><b>38 Series Pipe Thread Stem</b> Specify "38"</p>  <p><b>STEM 2</b> 3/4" Pipe Thread (1" actual stem diameter)</p> <p><b>STEM 3</b> 1" Pipe Thread (1-1/4" actual stem diameter)</p> <p><b>STEM 4</b> 1-1/4" Pipe Thread (1-1/2" actual stem diameter)</p>	<p><b>40 Series Expanding Adapter Stem</b> Specify "40"</p>  <p><b>9</b> 3/4" Tubing ID</p> <p><b>11</b> 7/8" Tubing ID</p> <p><b>13</b> 1" Tubing ID</p> <p><b>14</b> 1-1/8" Tubing ID</p> <p><b>17 B</b> 1-3/16" Tubing ID</p> <p><b>190 C</b> 1-3/8" Tubing ID</p> <p><b>19 A</b> 1-1/2" Tubing ID</p> <p><b>21</b> 1-7/8" Tubing ID</p>	<p><b>3S Hollow Rivet</b> Specify "3S"</p>  <p>Hollow kingpin casters are designed to accept a 3/8" diameter bolt or other stem type. Stem code not needed.</p>
---	--	---	--	--	---	--	--

See mounting details on page 13.



# Stainless Steel Light Duty

# S30 to S40 Series

Capacity to 325 pounds each

Polished grade 304 stainless steel designed to prevent rust and corrosion in the most demanding wet, damp and corrosive environments. Stainless steel is impervious to repeated washings, thereby reducing maintenance and providing longer caster life. All component metal parts including ball bearings, axle, nut, spanner bushing and dust cap are stainless steel.



5-S30-213GD PLT 2  
*(shown in photo)*

5-S32-113P  
*(shown in photo)*

## FEATURES

- ✓ **Finish:** Stainless steel
- ✓ **Dust Cap:** all swivel models feature dust cap which protects swivel raceway bearings and improves performance.
- ✓ **Swivel Construction:** stainless steel grade 440 ball bearings with hardened double raceway construction. Bearings are magnetic.
- ✓ **Axle:** 3/8" diameter stainless steel axle with lock nut.
- ✓ **King Pin:** 1/2" stainless steel rivet, hydraulically upset.
- ✓ **Grease Temperature Range:** -45°F to +260°F



Please work with your sales representative for compliance requirements on a part specific basis.

## CASTER OPTIONS

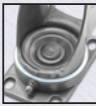
- ✓ **PosiLoc® Brake:** stainless steel construction; to order, add "PL" to end of model number. 
- ✓ **VertiLoc® Brake:** stainless steel construction; to order, add "VL" to end of model number. 
- ✓ **Swivel Lock:** Locks caster in trailing position at 180° while wheel spins freely. To order specify "1PSL" (swivel plate only). 
- ✓ **Swivel Grease Seal:** Includes zerk in the dust cap. To order, add "GS" to end of model number. 
- ✓ **Thread Guards:** Consult factory.
- ✓ **Optional Top Plate Sizes:** variety of top plate sizes available – consult factory.

## WHEEL OPTIONS



Advantage TPR Round

Advantage TPR Flat

Advantage Heat Round or Flat

Advantage Health Antimicrobial

Welded Disc Polyurethane

Polyolefin

Phenolic

PolyLoc Grey

Hi-Temp Resin



S30 Series Swivel

S31 Series Rigid

S32 Series Round Stem

S34 Series Spring Ring Stem

S36 Series Threaded Stem

S40 Series Expanding Adapter Stem

S30-S40 STAINLESS SERIES

Continues next page



# Stainless Steel Light Duty

# S30 to S40 Series

Capacity to 325 pounds each









Wheel Diameter (Inches)	Tread Width (Inches)	Wheel Type	Bearing	Capacity (Pounds)	Base Model Number	Approximate Weight (Pounds)	Load Height (Inches)	Swivel Radius (Inches)				
4	1 1/4	ADVANTAGE TPR / ROUND	DELRIN	250	4-___-314GD	2-1/4	5 1/16 (Plate) 4 15/16 (Stem)	3 1/2				
		ADVANTAGE TPR / FLAT	DELRIN	300	4-___-314GF	2-1/4						
		POLYOLEFIN	SS SLEEVE	300	4-___-513	2-1/4						
		POLYLOC / GREY	DELRIN	300	4-___-314G	2-1/4						
		ADVANTAGE HEAT FLAT <sup>1</sup>	SS BALL	300	4-___-213RTF	2-1/4						
		ADVANTAGE HEALTH	SS BALL	300	4-___-213MF	2-1/4						
	1 1/2	PHENOLIC	SS SLEEVE	300	4-___-121	2-1/4						
		HI-TEMP RESIN	PLAIN	300	4-___-521HT	2-1/4						
		5	1 1/4	ADVANTAGE TPR / ROUND <sup>2</sup>	SS BALL	250			5-___-213GD	2-3/4	6 1/8 (Plate) 6 (Stem)	4
				POLYOLEFIN	SS SLEEVE	300			5-___-513	2-3/4		
WELDED DISC / POLYURETHANE	SS SLEEVE			300	5-___-113P	2-3/4						
POLYLOC / GREY <sup>2</sup>	SS BALL			300	5-___-213G	2-3/4						
ADVANTAGE HEAT FLAT <sup>1</sup>	SS BALL			300	5-___-213RTF	2-3/4						
ADVANTAGE HEALTH	SS BALL			300	5-___-213MF	2-3/4						
ADVANTAGE TPR / FLAT	DELRIN			325	5-___-314GF	2-3/4						
1 1/2	PHENOLIC		SS SLEEVE	300	5-___-121	2-3/4						
	HI-TEMP RESIN		PLAIN	325	5-___-521NHT	2-3/4						
	6		1 1/4	ADVANTAGE TPR / ROUND	DELRIN	300	6-___-314GD	3-1/4	7 3/16 (Plate) 7 1/16 (Stem)	4 1/2		
POLYOLEFIN		SS SLEEVE		300	6-___-521	3-1/4						
POLYLOC / GREY <sup>1</sup>		SS BALL		300	6-___-213G	3-1/4						
ADVANTAGE HEAT FLAT		SS BALL		325	6-___-213RTF	3-1/4						
ADVANTAGE HEALTH		SS BALL		325	6-___-213MF	3-1/4						
PHENOLIC		SS SLEEVE		300	6-___-121	3-1/4						

To order, add caster series and if applicable mounting code to end of model number (Example: 5-**S30**-513 **PLT 2** or 5-**S32**-213GF)

<sup>1</sup>Delrin bearing also available, consult factory.

<sup>2</sup>Advantage Heat Round treads also available, change RTR to RTF.

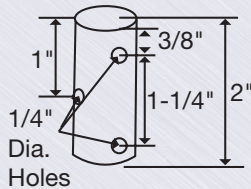
S30-S40 STAINLESS SERIES

S30 Series Swivel Specify "S30"	S31 Series Rigid Specify "S31"	S32 Round Stem Specify "S32"	S34 Series Spring Ring Stem Specify "S34"	S36 Series Threaded Stem Specify "S36"	S40 Series Expanding Adapter Stem Specify "S40"
					
<p><b>PLT 2</b> Dimensions: 2-3/8" x 3-5/8" Bolt Pattern: 1-3/4" x 3" (bolt size 5/16")</p> <p><b>PLT 3</b> Dimensions: 3-1/8" x 4-1/8" Bolt Pattern: 2-3/8" x 3-7/16" (bolt size 5/16")</p> <p><b>PLT 5</b> Dimensions: 3-3/4" x 4-1/2" Bolt Pattern: 2-5/8" x 3-5/8" to 3" x 3" (bolt size 3/8")</p>		<p><b>Standard Round Stem Size:</b> 3/4" diameter x 2" long with three drilled holes 1/4" diameter. Mounting code not needed (Example: 5-<b>S32</b>-113P)</p>  <p>Top View</p> 	<p><b>Standard Spring Ring Stem Size:</b> .845" diameter x 2-3/16" long.</p>	<p><b>Standard Threaded Stem Size:</b> 1/2" diameter – 13 x 1-1/2" long.</p> <p>Other stems available. Consult factory.</p>	<p><b>9</b> 3/4" Tubing ID</p> <p><b>11</b> 7/8" Tubing ID</p> <p><b>13</b> 1" Tubing ID</p> <p><b>14</b> 1-1/8" Tubing ID</p> <p><b>17 B</b> 1-3/16" Tubing ID</p> <p><b>190 C</b> 1-3/8" Tubing ID</p> <p><b>19 A</b> 1-1/2" Tubing ID</p> <p><b>21</b> 1-7/8" Tubing ID</p>

See mounting details on page 13.



# Medium Heavy Duty 130 to 136 Series

Capacity to 400 pounds each



5-130-522 PLT2  
(shown in photo)

## FEATURES

- ✓ **Design:** heavy gauge cold rolled steel, formed for strength and heat treated.
- ✓ **Dust Cap:** protects swivel raceway bearings and improves performance.
- ✓ **Finish:** bright zinc plating to resist rust and corrosion.
- ✓ **Swivel Construction:** double ball bearing with hardened raceways.
- ✓ **Axle:** Wheel sizes 3", 4" and 5" use 3/8" dia axle. Wheel sizes 6" and 8" use 1/2" diameter axle.
- ✓ **King Pin:** 1/2" steel rivet
- ✓ **Fork Leg Spacing:** 2"

## CASTER OPTIONS

- ✓ **VertiLoc® Brake:** to order, add "VL" to end of model number. 
- ✓ **Swivel Grease Seal:** Includes zerk grease fitting in dust cap. To order, add "GS" to end of model number. 
- ✓ **Optional Plate Sizes:** variety of plate sizes available – consult factory.



Please work with your sales representative for compliance requirements on a part specific basis.

## WHEEL OPTIONS



Cushion or Hard Rubber



Advantage TPR Flat



Phenolic



Polyolefin



PolyLoc Grey



PolyLoc Blue



132 Series Swivel



131 Series Rigid



134 Series Spring Ring Stem



136 Series Threaded Stem

130-136 SERIES

# Medium Heavy Duty 130 to 136 Series

Capacity to 400 pounds each

Wheel Diameter (Inches)	Tread Width (Inches)	Wheel Type	Bearing	Capacity (Pounds)	Base Model Number	Approximate Weight (Pounds)	Load Height (Inches)	Swivel Radius (Inches)
3	1 13/16	POLYOLEFIN	ROLLER	400	3-___-532	1-3/4	2 3/8 (Plate) 3 13/16 (Stem)	2 3/8
4	1 5/8	CUSHION / SOLID RUBBER	PLAIN	225	4-___-109	2-1/8	5 3/8 (Plate) 5 3/16 (Stem)	3 1/2
		CUSHION / SOLID RUBBER	ROLLER	225	4-___-209	2-1/8		
		HARD / SOLID RUBBER	PLAIN	400	4-___-110	2-1/8		
		HARD / SOLID RUBBER	ROLLER	400	4-___-210	2-1/8		
	1 1/2	PHENOLIC	PLAIN	400	4-___-121	2-1/8		
		PHENOLIC	ROLLER	400	4-___-221	2-1/8		
5	1 5/8	CUSHION / SOLID RUBBER	PLAIN	260	5-___-109	2-3/4	6 1/4 (Plate) 6 1/16 (Stem)	4
		CUSHION / SOLID RUBBER	ROLLER	260	5-___-209	2-3/4		
		HARD / SOLID RUBBER	PLAIN	400	5-___-110	2-1/2		
		HARD / SOLID RUBBER	ROLLER	400	5-___-210	2-1/2		
	1 1/2	PHENOLIC	PLAIN	400	5-___-121	2-1/2		
		PHENOLIC	ROLLER	400	5-___-221	2-1/2		
		POLYOLEFIN	PLAIN	400	5-___-521	2-3/4		
		POLYOLEFIN	ROLLER	400	5-___-522	2-3/4		
		ADVANTAGE TPR / FLAT	ROLLER	400	5-___-215GF	2-1/8		
		POLYLOC / GREY	ROLLER	400	5-___-215G	2-1/8		
		POLYLOC / BLUE	ROLLER	400	5-___-215P	2-1/8		
6	1 1/2	PHENOLIC	PLAIN	400	6-___-121	2-3/4	7 1/2 (Plate) 7 5/16 (Stem)	4 3/4
		PHENOLIC	ROLLER	400	6-___-221	2-3/4		
		POLYOLEFIN	DELTRIN	400	6-___-523	2-3/4		
		POLYOLEFIN	ROLLER	400	6-___-522	2-3/4		
		ADVANTAGE TPR / FLAT	ROLLER	400	6-___-215GF	2-3/4		
		POLYLOC / GREY	ROLLER	400	6-___-215G	2-3/4		
		POLYLOC / BLUE	ROLLER	400	6-___-215P	2-3/4		
8	1 1/2	ADVANTAGE TPR / FLAT	ROLLER	250	8-___-215GF	3	9 1/2 (Plate) 9 5/16 (Stem)	6 1/2
		POLYLOC / GREY	ROLLER	250	8-___-215G	3		
		POLYLOC / BLUE	ROLLER	250	8-___-215P	3		
		POLYOLEFIN	DELTRIN	250	8-___-523	3		
		POLYOLEFIN	ROLLER	250	8-___-522	3		

To order, add caster series and if applicable mounting code to end of model number (Example: 5-130-109 **PLT 1** or 5-134-215G **STEM 1**)

**130 Series Swivel**  
Specify "130"



**PLT 1**  
Dimensions: 2-3/8" x 3-5/8"  
Bolt Pattern: 1-3/4" x 3" (bolt size 1/4")

**PLT 2**  
Dimensions: 2-3/8" x 3-5/8"  
Bolt Pattern: 1-3/4" x 3" (bolt size 5/16")

**PLT 3**  
Dimensions: 3-1/8" x 4-1/8"  
Bolt Pattern: 2-3/8" x 3-7/16"  
(bolt size 5/16")

**PLT 4**  
Dimensions: 4" x 4"  
Bolt Pattern: 3" x 3" (bolt size 3/8")

**PLT 5**  
Dimensions: 3-3/4" x 4-1/2"  
Bolt Pattern: 2-5/8" x 3-5/8" to 3" x 3"  
(bolt size 3/8")

**PLT 7**  
Dimensions: 3-1/2" x 3-1/2"  
2-5/8" x 2-5/8" (bolt size 9/32")

Note: PLT 4 and PLT 5 rigid casters are two piece welded design. Consult factory.

**131 Series Rigid**  
Specify "131"



**134 Series Spring Ring Stem**  
Specify "134"



**STEM 1**  
3/4" diameter x 2-3/16" long

**STEM 2**  
13/16" diameter x 2-3/16" long

**STEM 3**  
.845" diameter x 2-3/16" long

**STEM 4**  
.865" diameter x 2-3/16" long

**STEM 5**  
1" diameter x 2-3/16" long

**STEM 6**  
.860" **SQUARE** x 2-3/16" long

**136 Series Threaded Stem**  
Specify "136"



**STEM 1**  
1/2" dia. -13 x 3/4" long

**STEM 2**  
1/2" dia. -13 x 1" long

**STEM 3**  
1/2" dia. -13 x 1-1/2" long

**STEM 4**  
1/2" dia. -20 x 3/4" long

**STEM 5**  
1/2" dia. -20 x 2-1/4" long

**STEM 6**  
5/8" dia. -11 x 1-1/4" long

**STEM 7**  
5/8" dia. -18 x 1-3/4" long

**STEM 8**  
3/4" dia. -10 x 1" long



# Bumpers



**4714-00**  
(Grey)



**4714-01**  
(Black)

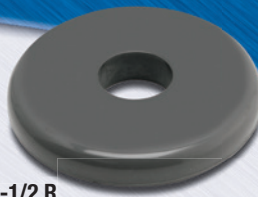

**B-3-1/2 R**  
(Round Stem)

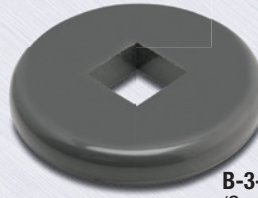

**B-3-1/2 S**  
(Square Stem)

**B-5**  
(Rolling Bumper)

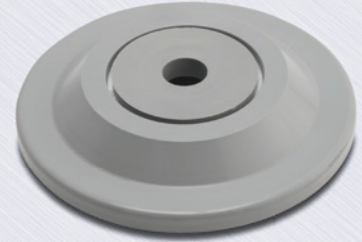

## End Bumper B-1

Grey or black end bumper generally used on the ends of tubular handles on carts and platform trucks. Designed to help protect equipment as well as walls and door facings. Bumper Dimensions: 3-1/4" diameter with steel insert for 5/16" mounting bolt.

## Tubing Bumper B-3-1/2

Designed to fit over 1" OD round or square tubing on carts and a variety of rolling equipment. Please specify round or square tubing when ordering. Specify **B-3-1/2 R** for round ID and **B-3-1/2 S** for square ID.

## Rolling Bumper B-5

5" diameter rolling bumper; tapered grey rubber bonded to zinc plated insert with removable center bushings to fit stem diameters from 3/8" to 1-1/8". Specify bumper **B-5**.

**4718-00**  
(Grey)



**4719-00**  
(Black)



**4720-01**  
(Grey)



**4721-01**  
(Black)



**4722-01**  
(Grey)



**4724-01**  
(Black)



## Corner Bumper B-8

Grey or black corner bumper for mounting on the corners of equipment, carts or any flat surfaces. Absorbs shock to protect equipment and walls, doors and furniture. Bumper Dimensions: 7/8" thick x 1" high x 2-5/8" long from inside corner on each side.

## Corner Bumper B-10

A heavy duty bumper with reinforced, rounded corner to protect equipment from shocks and bumps. Steel inserts inside bumper assures permanent mounting to equipment. Ends are tapered and rounded for added design appeal. Bumper Dimensions: 1" thick x 1-1/16" high x 3-1/16" long from inside corner on each side. Mounting holes are 13/64" diameter.

## Corner Bumper B-12

A common bumper used to protect a wide variety of mobile equipment and the surrounding environment from bumps and scrapes. This bumper is equipped with steel inserts and can be mounted on any flat surface. The ends of the bumper legs may be cut at notched area to make square ends. Bumper features steel inserts. Bumper Dimensions: 7/8" thick x 1" high x 3-1/8" long from inside corner on each side. **Grey bumper with no steel insert, order model number 4724-30.**

# Tubing Adapters

Plastic adapters accepts 7/16" diameter spring ring stem. Metal adapter accepts 7/16" diameter straight stem.



## Rubber Expanding Adapters

for Series 27, W27, 40, S40 and 60MG casters



Tube OD (Inches)	Plastic Round	Plastic Square	Metal
3/4-16 ga.	1085	1086	-
7/8-16 ga.	1087	1088	-
1-16 ga.	1089	1090	1070
1-18 ga.	1084	1091	1071
1-1/2-18 ga.	-	1082	-

Adapter Number	ID of Round or Square Tube (Inches)	Tube Size Range (Inches)	Adapter Kit Parts			
			Rubber Bushing	Top Knurled Nut	Plastic Bushing	Base Washer
9	3/4	0.720-0.851	1644-00	1421-02	1429-02	1709-02
11*	7/8	0.852-0.927	1645-00	1435-02	1432-02	1709-02
13	1	0.928-1.029	1646-00	1435-02	1432-02	1709-02
15	1-1/8	1.030-1.140	1647-00	1436-02	1431-02	1709-02
17B	1-3/16	1.178-1.303	1651-00	1441-02	1430-02	1709-02
19C*	1-3/8	1.360-1.425	1648-00	1438-02	1433-02	1709-02
19A	1-1/2	1.426-1.589	1649-00	1437-02	1434-02	1709-02
21	1-7/8	1.790-1.850	1650-00	1422-02	1440-02	1473-02









\*Stainless Steel knurled nut and base washer.







BUMPER / ADAPTERS

# Stem Dimensions

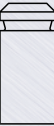

## Threaded Stems

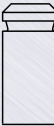
Drawing	Caster Series	Stem Size
	36 (Stem 1) 136 (Stem 1)	1/2" dia. - 13 x 3/4" long
	36 (Stem 2) 136 (Stem 2)	1/2" dia. - 13 x 1" long
	36 (Stem 3) 136 (Stem 3) S36 (Stem 3)	1/2" dia. - 13 x 1-1/2" long
	36 (Stem 4) 136 (Stem 4)	1/2" dia. - 20 x 3/4" long
	36 (Stem 5) 136 (Stem 5)	1/2" dia. - 20 x 2-1/4" long
	36 (Stem 6) 136 (Stem 6)	5/8" dia. - 11 x 1-1/4" long
	36 (Stem 7) 136 (Stem 7)	5/8" dia. - 18 x 1-3/4" long
	36 (Stem 8) 136 (Stem 8)	3/4" dia. - 10 x 1" long

## Spring Ring Stems

Drawing	Caster Series	Stem Size
	34 (Stem 1) 134 (Stem 1)	3/4" dia. x 2-3/16" long
	34 (Stem 2) 134 (Stem 2)	13/16" dia. x 2-3/16" long
	34 (Stem 3) 134 (Stem 3)	.845" dia. x 2-3/16" long
	34 (Stem 4) 134 (Stem 4) S34 (Stem 4)	.865" dia. x 2-3/16" long
	34 (Stem 5) 134 (Stem 5)	1" dia. x 2-3/16" long
	34 134 (Stem 6)	.860" Square x 2-3/16" long

## Pipe Thread Stem

Drawing	Caster Series	Stem Size
	38 (Stem 2)	3/4" Pipe Thread (1" actual stem dia.)
	38 (Stem 3)	1" Pipe Thread (1-1/4" actual stem dia.)
	38 (Stem 4)	1-1/4" dia. (1-1/2" actual stem dia.)

## Round Stem

Drawing	Caster Series	Stem Size
	S32	3/4" dia. round x 2"

## Octagon Stem

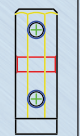
Drawing	Caster Series	Stem Size
	32	3/4" dia. by 2" long

# Top Plate Dimensions

Drawings are 30% scale reduction.

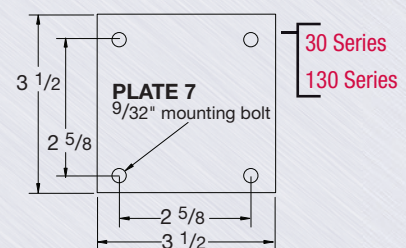
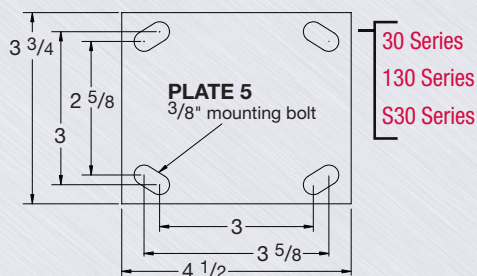
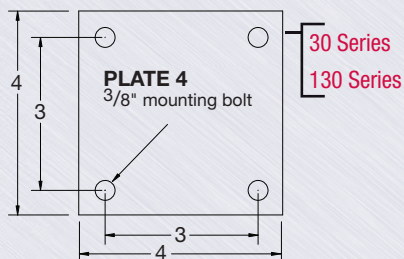
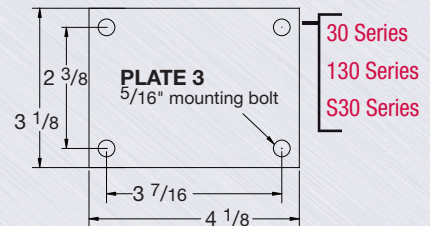
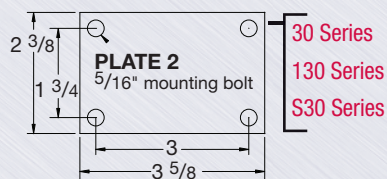
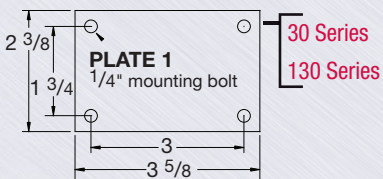



**COMMITTED TO YOUR SUCCESS**

**[JarvisCaster.com](http://JarvisCaster.com)**



**Jarvis Caster Company**  
800-253-0868 • [www.jarviscaster.com](http://www.jarviscaster.com)

*All specifications and dimensions  
are accurate for present  
manufacture but subject to  
change without notice.*



**THE GLOBAL LEADER**  
IN CASTERS AND WHEELS.

©2025 Jarvis Caster • CGP010.1024.r3